

# TEMPERATURE CONTROLS

## REMOTE / DIRECT SENSING

Type LWS, FWS, RWS & EWS

SAGINOMIYA

### GENERAL DESCRIPTION

- Most suitable model can be selected from the variations of wide temperature range with either adjustable or fixed differential. Narrow differential is further advantageous.
- Sensing elements are air sensed and liquid sensed type depending on control media. Also, sensing element can be selected from remote or direct type depending on application.
- Single pole double throw contacts allows use for either heating or cooling application, with large contact rating as well.
- Adjusting mechanism is driver adjusting type as standard on delivery, but a knob assembly and a concealed plate are also supplied as standard accessories.

**UL** listed (available upon request)



Type LWS



Type EWS

### TYPE NUMBER SELECTION (SPECIFICATIONS)

Type LWS—Set high type with standard remote sensing element.

Unit: °C

Catalog No.						Temp. Adjusting Range		Differential		Bulb Size (mm)	Ambient Temp.	Limit of Bulb Temp.	Wt. (kg)
Type	Contact	Model	Differential	Rating	Capillary Length	Min.	Max.	Min.	Max.				
LWS	C1	030	A (Variable)	G	Standard L1 (L=1m) Option L2 (L=2m) L3 (L=3m) L5 (L=5m)	-35	30	2	7	$\phi$ 9.5×100	-20 to 70	0.45	60
		060				-5	60						90
		090				25	90						120
		120				40	120	150					
		160				95	160	185					
		200				135	200	230					
		240	175	240	265								
		030	F (Fixed)	R	Standard L1 (L=1m) Option L2 (L=2m) L3 (L=3m) L5 (L=5m)	2 (Fixed)	$\phi$ 9.5×100	60					
		060						-5	60	90			
		090						25	90	120			
		120						40	120	150			
		160				95	160	185					
		200				135	200	230					
		240				175	240	265					
2.5 (Fixed)	$\phi$ 9.5×70	60											

- Manual Reset Models of LWS-C1030F and LWS-C1060F for low limit application are available upon request.
- Knob assembly and control plate are supplied as standard accessories.

Type FWS—Air Sensed type with standard remote sensing element.

Unit: °C

Catalog No.						Temp. Adjusting Range		Differential		Bulb Size (mm)	Ambient Temp.	Limit of Bulb Temp.	Wt. (kg)
Type	Contact	Model	Differential	Rating	Capillary Length	Min.	Max.	Min.	Max.				
FWS	C1	030	A (Variable)	G	Standard L1 (L=1m)	-35	30	2	7	Max. $\phi$ 37×58	-20 to 70	0.52	60
		060				-5	60						90
		090				25	90	120					
		120				40	120	150					
		030	F (Fixed)	R	Option L2 (L=2m) L3 (L=3m) L5 (L=5m)	2 (Fixed)	$\phi$ 37×58	60					
		060						-35	30				90
		090				-5	60	120					
		120				25	90	150					

Type RWS—with coiled capillary sensing element.

Unit: °C

Type	Catalog No. Designation				Temp. Adjusting Range		Differential		Sensing Element (mm)	Ambient Temp.	Limit of Tube Temp.	Wt. (kg)
	Contact	Model	Differential	Rating	Min.	Max.	Min.	Max.				
RWS-	C1	060	F (Fixed)	R	-5	60	2 (Fixed)		Coiled Tube Max. $\phi$ 42×40	-20 to 70	70	0.43
		034			-10	35	1.4(Fixed)			-20 to 60	60	
		054			10	55				-20 to 70	70	
		060	A (Variable)		-5	60	2	7		-20 to 70	70	
		034			-10	35	1.4	5		-20 to 60	60	
		054			10	55				-20 to 70	70	

Type EWS—with direct immersion sensing element.

Unit: °C

Type	Catalog No. Designation				Temp. Adjusting Range		Differential		Sensing Element (mm)	Ambient Temp.	Limit of Tube Temp.	Wt. (kg)
	Contact	Model	Differential	Rating	Min.	Max.	Min.	Max.				
EWS-	C1	080	F (Fixed)	R	0	80	2.5 (Fixed)		$\phi$ 10.8×70	-20 to 70	110	0.51
		120			40	120					150	
		160			95	160					185	
		080	A (Variable)		0	80	2.5	8			110	
		120			40	120					150	
		160			95	160					185	

ELECTRICAL RATINGS

Electrical Rating Code	Rated Amps. (A)	Rated Voltage (V)		Power Factor (cos $\phi$ )	125V. AC	250V. AC
		125V. AC	250V. AC		125V. AC	250V. AC
G	Non-Inductive Current		1.0	0.5 to 16	0.5 to 8	0.5 to 8
	Inductive Current	Full Load	0.75			
		Locked Rotor	0.45			
R	Non-Inductive Current		1.0	0.05 to 8.5	0.05 to 4.5	0.05 to 4.5
	Inductive Current	Full Load	0.75			
		Locked Rotor	0.45			

CONTACT STYLE

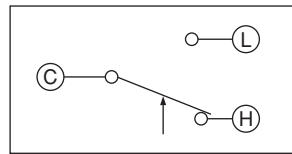

Models "set high"

The dial indicates the high switch point (© - © close, © - © open).

The low switch point (© - © open, © - © close) is obtained by deducting the differential from the high switch point.

Arrow mark indicates a direction of switch action on temperature increase.

DIMENSIONS

Type LWS

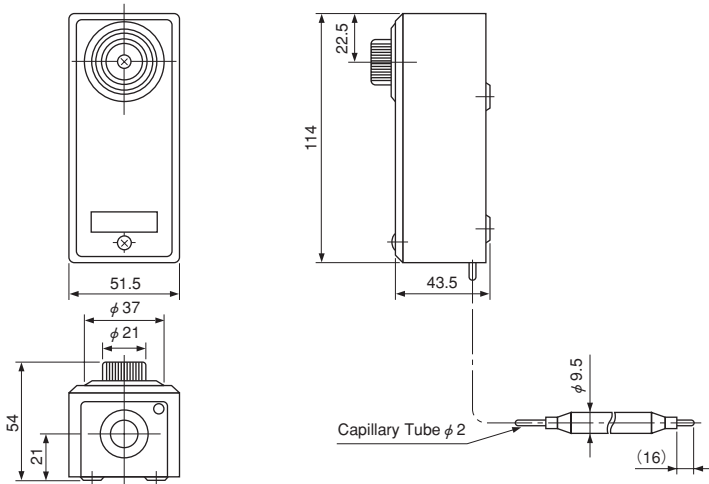

Type FWS

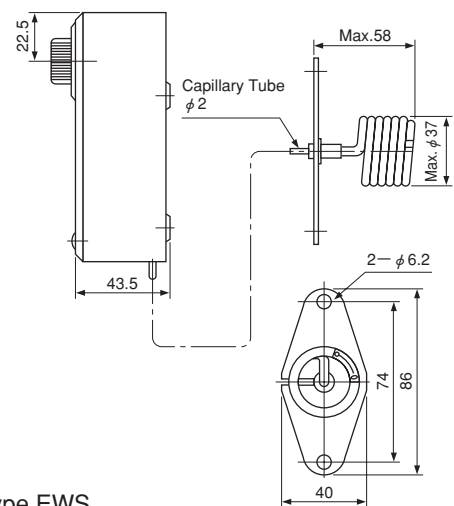

Type RWS

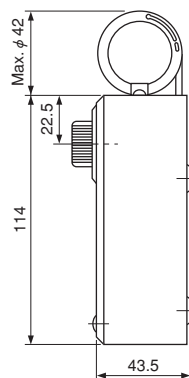

Type EWS

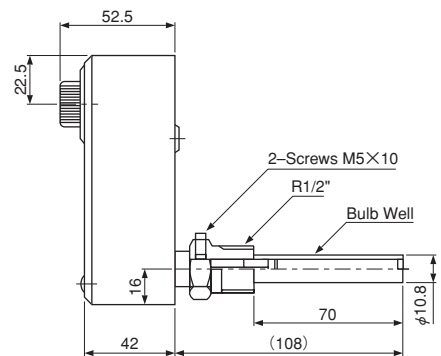

Unit: mm